

**CODE NUMBER**

24601200

**DESCRIPTION**

ST-2469 Water Closet and SOLIS 8152 Flushometer.

**COMPONENTS**

- Flushometer: Code 3370060
- Water Closet: Code 2102469

**DETAILS**

- Flush Volume: 1.28 gpf (4.8 Lpf)
- Nominal Dimensions: 26 ¾" x 15" x 16 ¾" (679 x 381 x 425mm)

**FLUSHOMETER FEATURES**

- Infrared Sensor with Multiple-focused, Lobular Sensing Fields for high and low target detection
- Low Battery Flashing LED
- Solar Powered. The sensor assembly is powered by a solar cell that will harvest power from the artificial indoor light (incandescent, fluorescent or LED), and use it as the energy source. The solar cell can provide approximately 100% power with 650 illuminance (lux).
- Four (4) Size AA Battery Back-up Power Source
- ADA Compliant Solis® Solar Powered Infrared Sensor for automatic "No Hands" operation
- Synthetic rubber seals for chloramine resistance
- User friendly three (3) second Flush Delay
- High Back Pressure Vacuum Breaker Flush Connection with One piece Bottom Hex Coupling Nut
- Spud Coupling and Flange for 1-1/2" concealed Rear Spud
- Fixed Metering Bypass and No External Volume Adjustment to Ensure Water Conservation
- 1" I.P.S. Wheel Handle Bak-Chek® Angle Stop
- Diaphragm, Stop Seat and Vacuum Breaker to be molded from PERMEX® rubber compound for Chloramine resistance
- WaterSense compliant when used with a 1.28 gpf WaterSense fixture

**FIXTURE FEATURES**

- White Vitreous China
- Elongated bowl
- Wall mounted, wall outlet
- Siphon jet flushing action achieves 1000g Map score when used with any Sloan flushometer
- Static load rating of 750 lbs (see Notes)
- Water spot area: 10 ½" x 9 ¾" (26 cm x 24 cm)
- 1½ I.P.S. rear spud inlet
- 2 ½" fully glazed trapway
- Toilet seat not included
- Static load rating of 750 lbs. (See Notes)



**COMPLIANCES & CERTIFICATIONS**

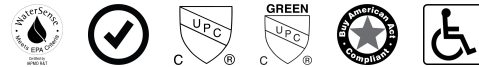

(WaterSense Listed, Satisfies LEED Credits, cUPC Certified, cUPC Green Certified, BAA Compliant, ADA Compliant)

**DOWNLOADS**

- [ST-2469 Installation Instructions](#)
- [Solis 8152/8195 SWB Installation Instructions](#)
- [Additional Downloads](#)

**NOTES**

All information contained within this document subject to change without notice.

Static load tested according to the procedure outlined in Section 6.7 of ASME A112.19.2. Not recommended for bariatric use.

**Sloan 10500 Seymour Ave, Franklin Park, IL 60131**

Phone: 800.982.5839 • Fax: 800.447.8329 • [sloan.com](http://sloan.com)

**ROUGH-IN**

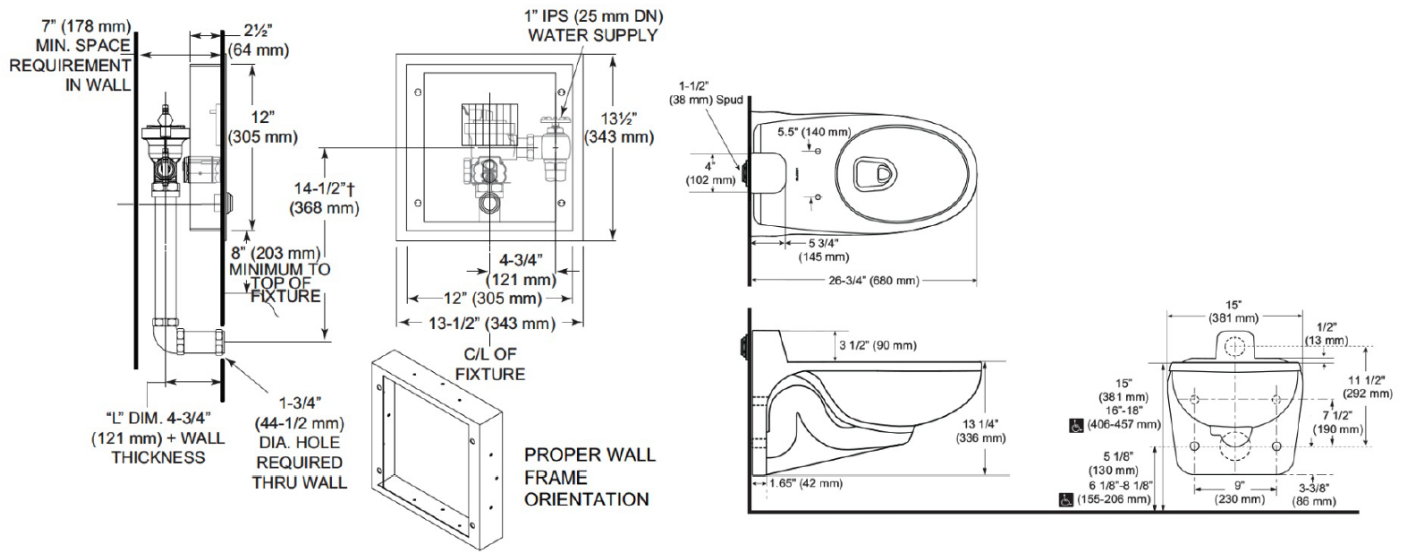

Sloan 10500 Seymour Ave, Franklin Park, IL 60131

Phone: 800.982.5839 • Fax: 800.447.8329 • [sloan.com](http://sloan.com)